

Please return to: NRK

Name: ANS.....

Form: .....

Teacher's Initials: .....

# ALLEYN'S SCHOOL

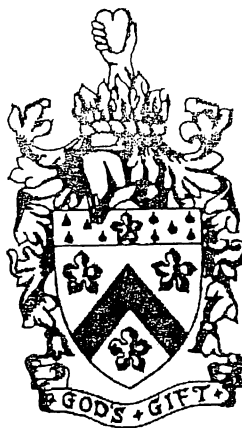

TOTAL  
100

## MATHEMATICS EXAM

YEAR 9

Calculator Paper

Paper 2

SUMMER EXAMINATION

JUNE 2009

Time allowed 1 hour 15 minutes

Calculators **MAY** be used.

Show your working as there may be marks given for working out.

There are **17 questions** on the paper. If you cannot answer a question, leave it and go on to the next question.

1. Find the angle x in each polygon

(i)

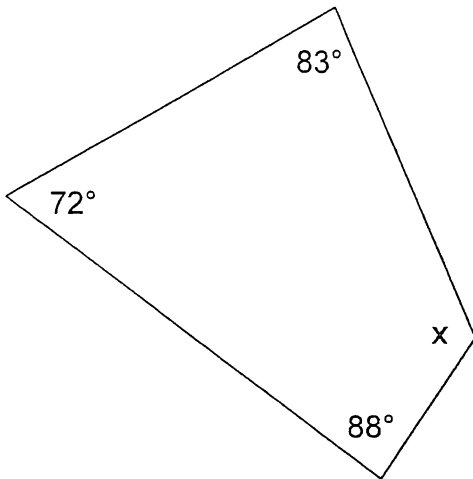

$$x + 88 + 72 + 83 = 360^\circ$$
$$x + 273 = 360$$

Ans: 117° [2]

(ii)

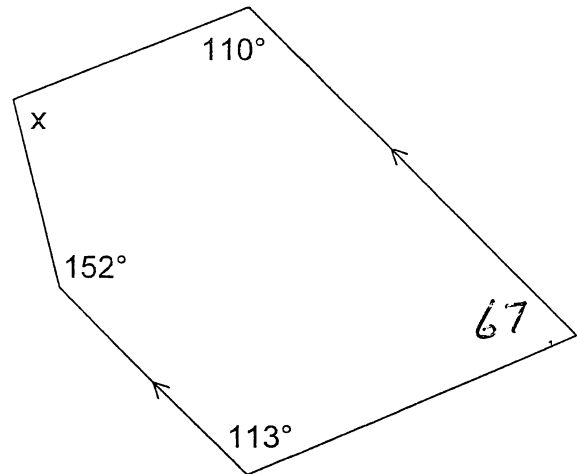

$$x + 110 + 67 + 113 + 152 = 540$$
$$x + 442 = 540$$

Ans: 98° [3]

2. A letter is picked at random from the twenty six letters in the alphabet. What is the probability it is a vowel?

Ans:  $\frac{5}{26}$  [1]

3. In each graph find the gradient and the y-intercept of the line

(i)

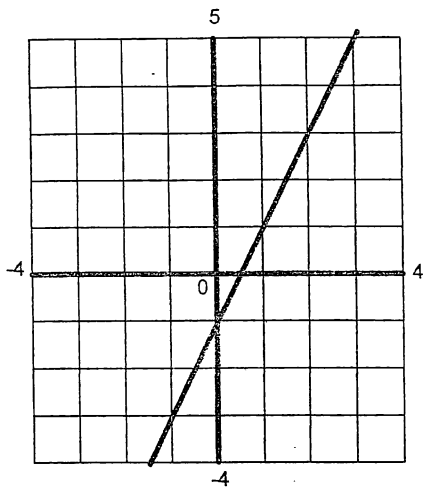

Ans: gradient = 2 [1]

Ans: y intercept = -1 [1]

(ii)

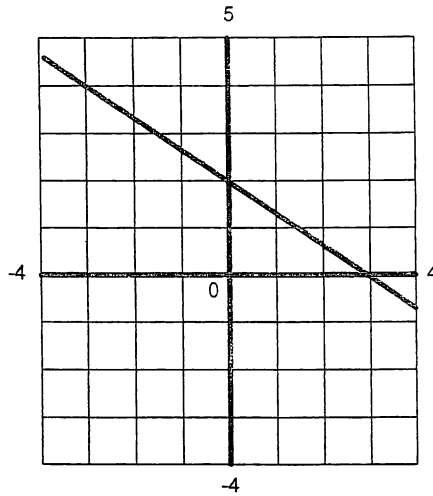

Ans: gradient =  $-\frac{2}{3}$  [1]

Ans: y intercept = 2 [1]

4. From each equation write down the gradient and the y-intercept:

(i)  $y = 4x - 6$

Ans: gradient = 4 [1]

Ans: y intercept = -6 [1]

(ii)  $2y - 3x = 8$

$2y = 3x + 8$   
 $y = 1\frac{1}{2}x + 4$

Ans: gradient = 1.5 [2]

Ans: y intercept = 4 [2]

5. In the triangle  $x$  is the marked angle. In the spaces provided, fill in the trigonometry names of the sides.

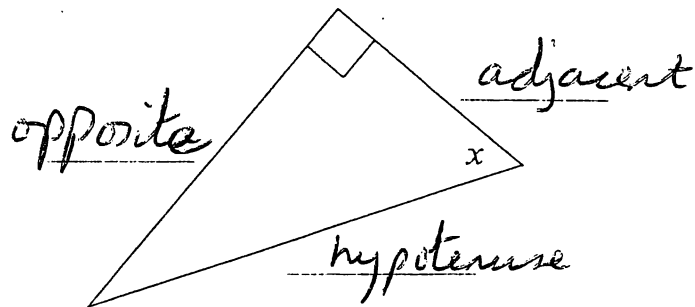

[3]

6. Find the side  $x$  in each of the following diagrams giving your answers to two decimal places.

(i)

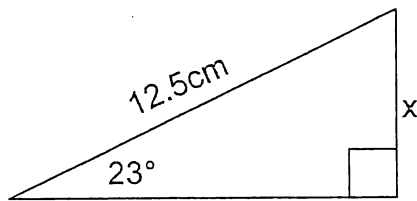

$$\frac{x}{12.5} = \sin 23^\circ$$

$$x = 12.5 \times \sin 23$$

$$4.8841$$

$$4.88$$

Ans: \_\_\_\_\_ [3]

(ii)

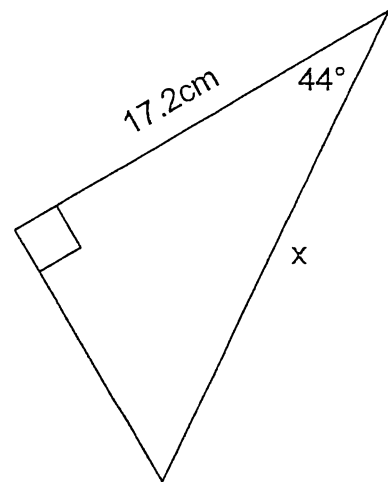

$$\frac{17.2}{x} = \cos 44$$

$$17.2 = x \times \cos 44$$

$$\frac{17.2}{\cos 44} = x \quad \parallel \quad x = 23.910$$

$$23.91$$

Ans: \_\_\_\_\_ [3]

7. In the triangle find the missing angle  $x$ . Give your answer to one decimal place.

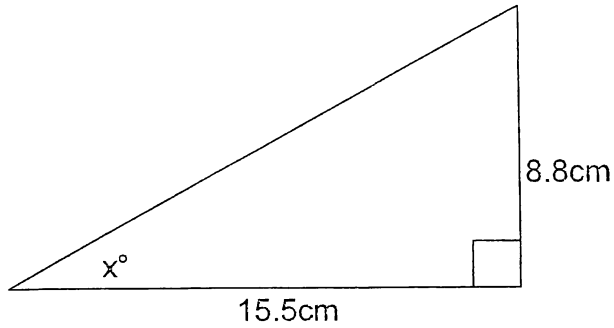

$$\tan x = \frac{8.8}{15.5}$$

$$x = \tan^{-1}\left(\frac{8.8}{15.5}\right) \quad x = 29.585$$

Ans: 29.6 [3]

8. The two polygons are similar. Find the lengths  $x$  and  $y$  of the missing sides. (Give your answers to 2 decimal places)

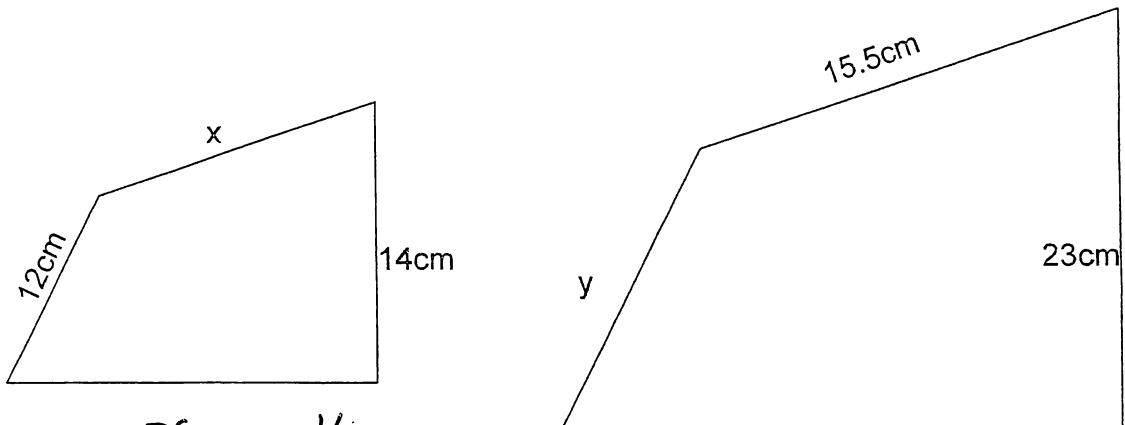

$$\frac{x}{15.5} = \frac{14}{23}$$

$$x = \frac{15.5 \times 14}{23} = \frac{217}{23} = 9.4347$$

Ans: ~~10.1~~ 9.43 [3]

$$\frac{y}{12} = \frac{23}{14}$$

$$y = \frac{12 \times 23}{14} = 19.714$$

Ans: 19.71 [3]

9. Find the areas of the following shapes.

(i)

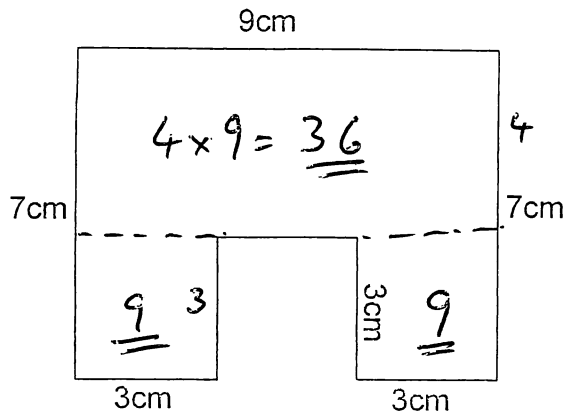

$$36 + 9 + 9$$

Ans: 54 cm<sup>2</sup> [3]

(ii)

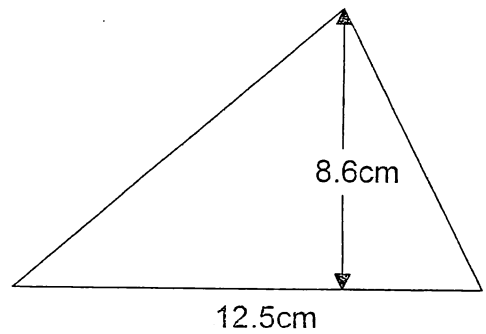

$$\begin{aligned} \text{Area} &= \frac{1}{2} \times 12.5 \times 8.6 \\ &= 53.75 \end{aligned}$$

Ans: 53.75 cm<sup>2</sup> [3]

10. Find the area and circumference of a circle with radius 6.3 cm (take  $\pi = 3.14$ , or use the value on your calculator) (Give your answers to 2 decimal places)

$$\begin{aligned} \text{Area} &= \pi r^2 \\ &= \pi \times 6.3^2 \\ &= 124.6898 \\ \text{or } 3.14 \times 6.3^2 \\ &= 124.626 \end{aligned}$$

$$\begin{aligned} \text{Circ} &= 2\pi r \\ &= 2 \times \pi \times 6.3 \\ &= 39.584 \\ \text{or } 2 \times 3.14 \times 6.3 \\ &= 39.564 \end{aligned}$$

$\pi$   
(3.14) Area = 124.69 cm<sup>2</sup> [3]  
or 124.63

( $\pi$ ) Circumference = 39.58 cm [3]  
(3.14) 39.56

11. (i) A book costs £5.60 but in a sale it is reduced by 40%.  
What is the sale price?

$$\underline{\underline{\pounds 5.60 \times 0.6 = 3.36}}$$

or  $5.60 \times \frac{40}{100} = \pounds 2.24$

$$\begin{array}{r} \pounds 5.60 \\ - 2.24 \\ \hline 3.36 \end{array}$$

Ans: £3.36 [2]

- (ii) The value of an antique clock increases from £550 to £748.  
What percentage increase is this?

$$\begin{aligned} \text{Increase} &= \pounds 748 - 550 \\ &= 198 \end{aligned}$$

$$\% \text{ Increase} = \frac{198}{550} \times 100 = 36$$

Ans: 36% [3]

- (iii) After a pay increase of 15% a man earns £14.26 an hour.  
What was his hourly pay rate before the increase?

$$x \times 1.15 = \pounds 14.26$$

$$x = \frac{14.26}{1.15} = 12.4$$

Ans: £12.40 [3]

- (iv) V.A.T. at the moment is 15%. It will go up to 17.5% later this year.  
If I buy a camera for £360 plus V.A.T., how much will I save if I buy it before V.A.T. goes up?

$$\begin{aligned} \text{Save } 2\frac{1}{2}\% \text{ of } \pounds 360 \\ &= \frac{2.5}{100} \times \pounds 360 \\ &= \pounds 9 \end{aligned}$$

or VAT

$$\begin{array}{r} 17\frac{1}{2}\% \text{ of } 360 = \pounds 63 \\ 15\% \text{ of } 360 = \pounds 54 \\ \hline \text{Save } \pounds 9 \end{array}$$

Ans: £9 [3]



14. Use trial and improvement to solve the following equation to 1 decimal place

$$x^2 + 3x = 46$$

x	$x^2 + 3x$	Too High / Low
3	$3^2 + 3 \times 3 = 18$	Low
<del>4</del>	<del><math>4^2 + 3 \times 4 = 16 + 12 = 28</math></del>	Low
<del>5</del>	<del><math>5^2 + 3 \times 5 = 25 + 15 = 40</math></del>	Low
4	$4^2 + 3 \times 4 = 16 + 12 = 28$	Low
5	$5^2 + 3 \times 5 = 25 + 15 = 40$	Low
		High
6	$6^2 + 3 \times 6 = 36 + 18 = 54$	High
5.2	$5.2^2 + 3 \times 5.2 = 42.64$	Low
5.3	$5.3^2 + 3 \times 5.3 = 43.99$	Low
5.4	$5.4^2 + 3 \times 5.4 = 45.36$	Low
5.5	$5.5^2 + 3 \times 5.5 = 46.75$	High
5.45	$5.45^2 + 3 \times 5.45 = 46.0525$	High
↑	5. if done using closest value.	
6 if	5.45 done	
$(5.4462)$		

Ans: 5.4 [6]

16

15. On a Christmas tree farm the heights of one hundred trees are measured in July and are recorded in a frequency table. Complete the Cumulative Frequency column.

Height of Tree	Frequency	Cumulative Frequency
80cm - 90cm	4	4
90cm - 100cm	12	16
100cm - 110cm	27	43
110cm - 120cm	31	74
120cm - 130cm	15	89
130cm - 140cm	9	98
140cm - 150cm	2	100

(2)

Draw a cumulative frequency graph and use it to find the median, the lower quartile, the upper quartile and the inter-quartile range.

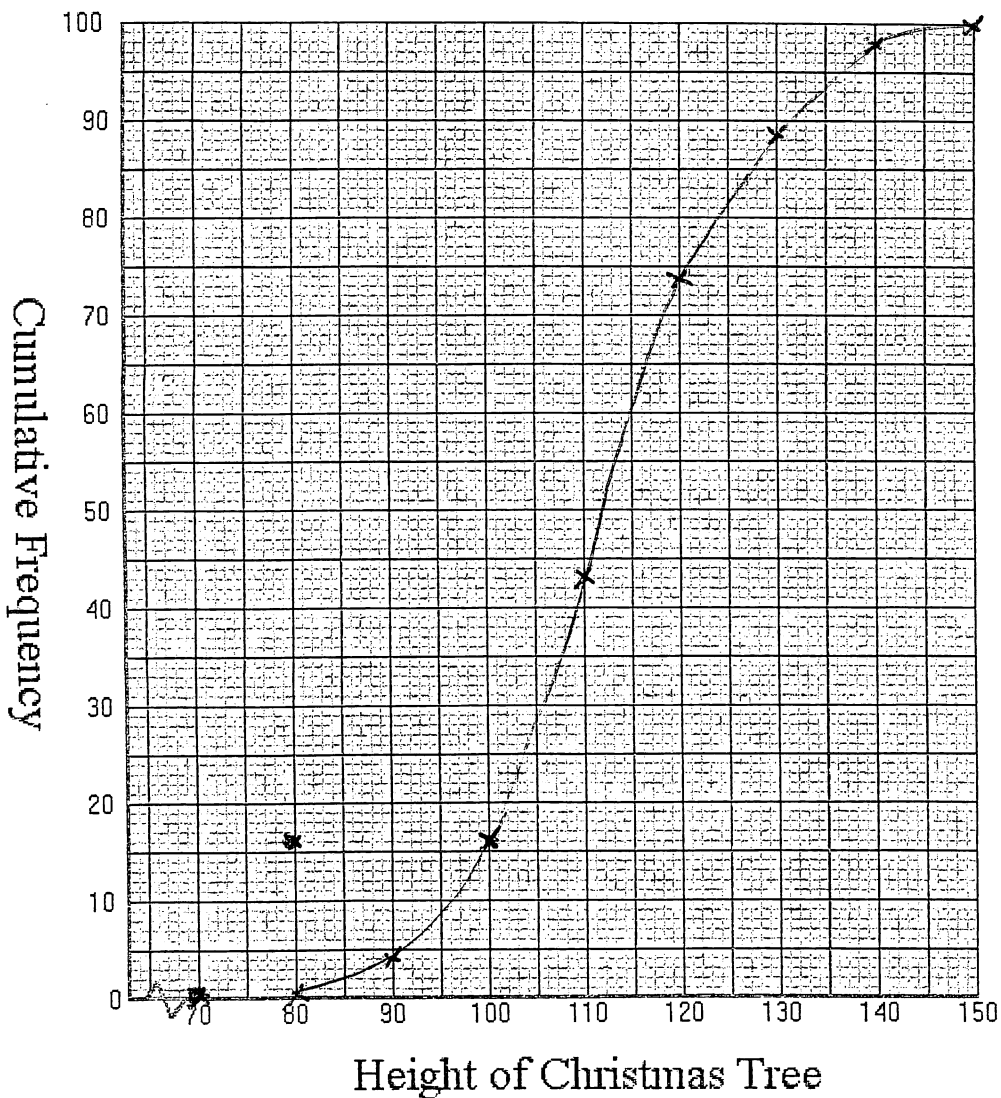

(3)

Median = 112

Lower Quartile = 104

Upper Quartile = 121

121 - 104

Inter-quartile range = 17

[9]

9

16. Complete the table below and draw the graph of the equation  $y = x^2 - 4x - 9$

x	-3	-2	-1	0	1	2	3	4	5	6
$x^2$	9	4	1	0	1	4	9	16	25	36
$-4x$	12	+8	4	0	-4	-8	-12	-16	-20	-24
$-9$	-9	-4	-9	-9	-9	-9	-9	-9	-9	-9
y	12	3	-4	-9	-12	-13	-12	-9	-4	3

(3)

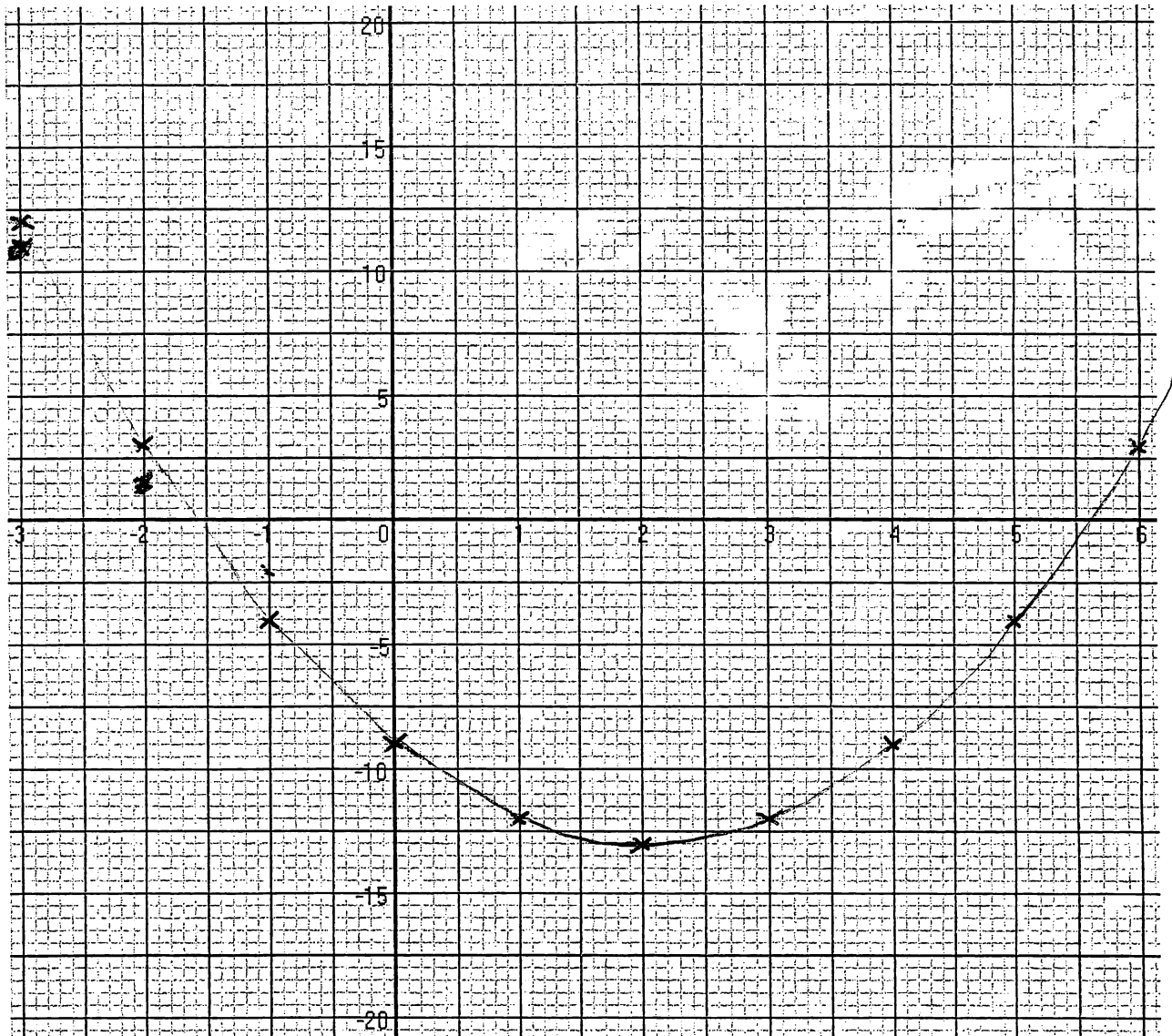

(4)

Use the graph to solve the equation  $x^2 - 4x - 9 = 0$

(2)

Ans:  $x = -1.6, 5.6$  [9]

$(-1.6055)(5.6055)$

(9)

17. A cylinder has a diameter of 9 cm and a height of 16 cm. It is filled with water. Find the volume of water it contains. (take  $\pi = 3.14$ , or use the value on your calculator)  
(Give your answer to one decimal place.)

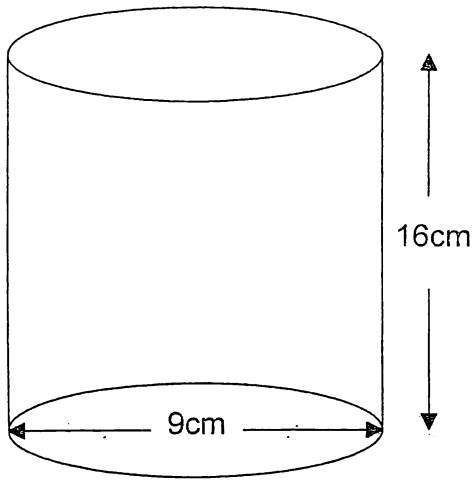

$$V_{\text{cyl}} = \pi \times (4.5)^2 \times 16$$

$$1017.876$$

$$\left( \begin{array}{l} \pi = 3.14 \\ \text{or } 1017.36 \end{array} \right)$$

$$(1017.4)$$

Ans: Volume = 1017.9 [3]

The water is now poured into an empty cube with side 12 cm. When all the water is poured in how deep will it be? (Give your answer to two decimal places.)

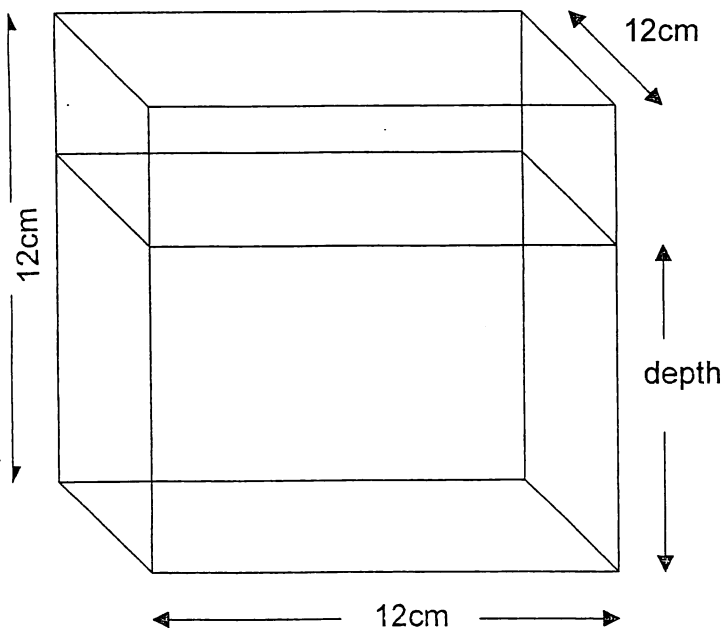

$$12 \times 12 \times \text{depth} = 1017.9$$

$$\text{depth} = \frac{1017.9}{144}$$

$$= 7.0685$$

$$(\text{or } 7.065)$$

Ans: Depth = 7.07 [3]

6